



Neuron

COMPRESS

Visually lossless, ultra-low latency, multichannel JPEG XS compression



Due to constant product research and development, all specifications are subject to change without notice. EVS does not warrant or assume any legal liability or responsibility for the accuracy, completeness, availability and/or delivery of the products and/or services listed in this datasheet. Copyright © 2022 EVS

Block schematics of configurations

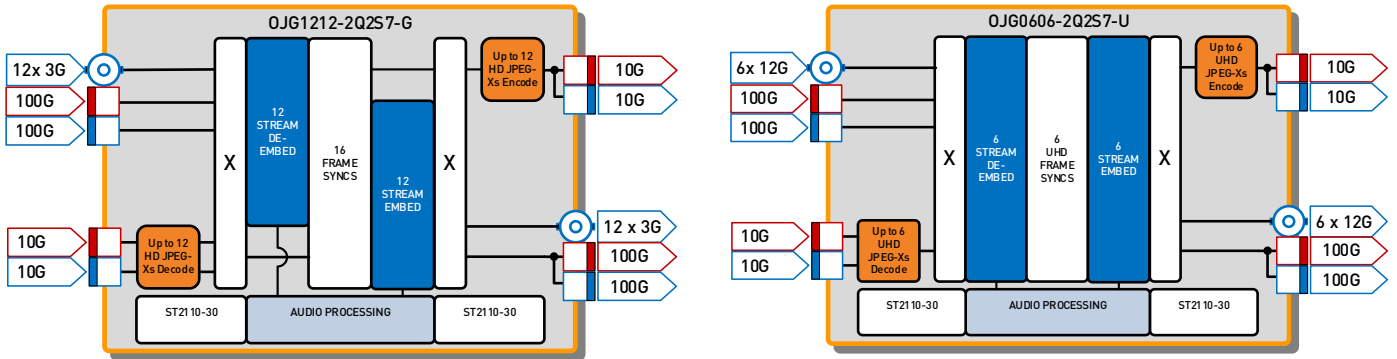

I/O Panel

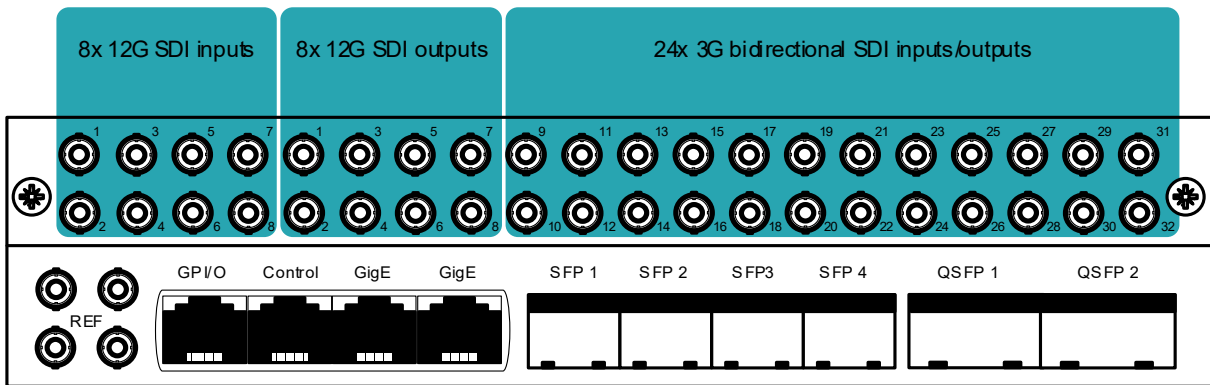

I/O of configurations

	SDI Inputs	IP Inputs	SDI Outputs	IP outputs
OJG1212-2Q2S7-G	32 ¹	24 ¹ & 3 ³	32 ¹	24 ¹ & 3 ³
OJG0606-2Q2S7-U	8 ²	12 ² & 3 ³	8 ²	12 ² & 3 ³

¹) amount of FHD (1080p50/59.94) channels

²) amount of UHD (2160p50/59.94) channels

³) Redundant streams

Processing paths A - D

The COMPRESS configurations can encode and decode UHD, FHD, HD and SD signals. The COMPRESS has multiple processing paths with de-embedding, synchronization and JPEG XS encoding outputting the signal on ST2110-22. The de-embedded audio can be bridged to ST2110-30 audio.

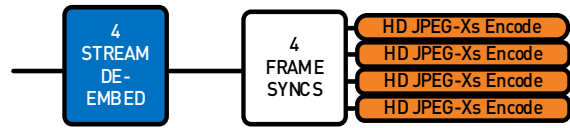

The COMPRESS also has multiple processing paths with embedding, synchronization and JPEG XS encoding outputting the signal on ST2110-22. The embedders allow for the embedding of incoming audio bridged from the ST2110-30 streams.

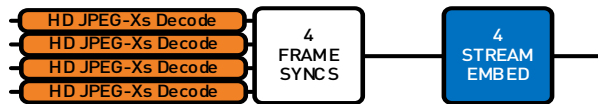

Features

COMPRESS consists of various configurations with JPEG XS decoding and encoding. The JPEG XS (ISO/IEC 21122) standard is a lightweight low latency image and video compression algorithm (codec) that maintains visually transparent compression. The typical compression ratio is between 1:6 and 1:12, so a UHD signal which uses 12Gb/s normally, would require 1Gb/s after JPEG XS compression and is still visually lossless. The configurations are available with various numbers of JPEG encoders and decoders (12+4 in HD).

The COMPRESS configurations are all multi-channel A/V-over-IP transceivers developed for use within low-latency and high-bandwidth Ethernet IP networks. SDI, ST2022 and ST2110 standards are both supported.

Besides encoding and decoding, the COMPRESS configurations have frame synchronizers on each processing path. The Encoder paths have audio de-embedders, and the Decoder paths have audio embedding. The audio embedders can embed audio from a 512 audio channel matrix.

Optionally, the COMPRESS line can be enhanced with an SDI I/O module. This will add 40 physical HD-BNC connectors and allows easy integration of video over IP networking with existing SDI baseband operations acting as bridge or gateway.

- Cost efficiency by integrating IT equipment and speed in a broadcast environment. Lowering cable cost and scalable systems.
- Standards supported: UHD, 3G-SDI level A, HD-SDI, ST2022-6 and ST2110-20/22/30.
- ST2110-22 streams in and out available on 10GbE interfaces
- JPEG XS Encoding output as ST2110-22
- JPEG XS Decoding received as ST2110-22
- Processing channels can be used in transparent mode allowing for gateway functionality
- Up to 24 IP video listeners and 24 IP audio listeners
- Up to 16 channels of bridging SDI to/from Ethernet (requires SDI optional board)
- Up to 16 channel frame-sync to local clock on external ref (B&B or ST2059)
- Up to 16 times 16 channel audio de-embedding
- Up to 16 times 16 channel audio embedding
- Up to 16 times Proc-amp for RGB and RGB-Black gains
- 512 channels audio gain/phase and offset delay
- Mono channel audio matrix (256ch de-embedded audio, 256ch ST2110-30 I/O and MADI IO)
- Clean switch and fast switch capabilities between all inputs (IP and/or SDI)
- Clean switch between incoming SDI and IP signals
- Each SDI or IP input can be used as a back-up signal for an SDI or IP output
- Redundant IP signals in and out (output port replication, ST2022-7 compliant)
- PTP Network timing with slave functionality on the Ethernet ports, compliant with SMPTE ST2059-2 External black burst inputs
- Audio synchronization
- 2x Analog bi-level reference out
- Multicast and unicast selectable per streams
- Selectable VLAN and priority per stream
- Compatible protocols: ACPv2, DNS, IGMPv2, IGMPv3, LLDP, HDCP, SDP, NMOS IS04, NMOS IS-05, 802.1as, ST2059-1/2, ST2022-6/7, ST2110-20/22/30

Applications

- Transport over video links and IP networks
- Point to point (back-to-back) applications for direct replacement of CWDM systems (with Opt-I/O A) with up to 12:1 compression using JPEG XS codecs
- Enabling local or remote productions over private or commercial networks
- IP production infrastructure

Ordering information

Hardware options:

- **NBASE-BOARD:** Neuron base processing board
- **NSDI40-BOARD:** Neuron SDI IO board, with 8x 12G in, 8x 12G out and 24 bidirectional IO on HD BNC

Configuration Compress (please select ONE of below line items) ! Caution this unit has no codec in its standard configuration

OJG1212-16-G 16 channel compression unit for **FHD JPEG XS TRANSCODER** applications includes 16 framesyncs and 16x embedding/de-embedding, IP & SDI IO

Option to add JPEG XS encoder (please add ONE of below line items, maximum of 12 per board)

COM-JPEG XSEG JPEG XS FHD encoder

Option to add JPEG XS decoder (please add ONE of below line items, maximum of 12)

COM-JPEG XSDG JPEG XS FHD decoder

Option to add proc-amp and RGB color correction (please add ONE of below line items, maximum of 2)

COM-PROC8 proc-amp and RGB color correction channels 1-8 (2x UHD)

Option to add audio shuffling, delay, gain and phase (please add ONE of below line items)

COM-APR512 Audio Processing option for 512 channels Gain/phase/delay

Configuration Compress (please select ONE of below line items) ! Caution this unit has no codec in its standard configuration

OJG0606-6-U 8 channel compression unit for **UHD JPEG XS TRANSCODER** applications includes 8 framesyncs and 8 embedding/de-embedding, IP IO

Option to add JPEG XS encoder (please add ONE of below line items, maximum of 6)

COM-JPEG
XSEU1 JPEG XS UHD encoder for channel 1

Option to add JPEG XS decoder (please add ONE of below line items, maximum of 6)

COM-JPEG
XSDU1 JPEG XS UHD decoder for channel 1

Option to add proc-amp and RGB color correction (please add ONE of below line items)

CON-PROC8 proc-amp and RGB color correction channels 1-8 (2x UHD) **requires OJG0606-6-U**

Option to add audio shuffling, delay, gain and phase (please add ONE of below line items)

COM-APR512 Audio Processing option for 512 channels Gain/phase/delay

Specifications

Reference I/O

Connector Type	Micro BNC (HD BNC)
Number of inputs	2
Number of outputs	2, Loop input or analog reference out
Termination	75 Ohms when not looped
Bi-Level	PAL/NTSC Black Burst ITU624

Gigabit Ethernet

Connector Type	RJ45
Number	1 (2 for future use)
Standards	10/100/1000 Base-T
Protocols streaming	AES67, ST2059
Protocol control	ACpv2
Cable	Shielded twisted pair

QSFP Cages

Number of cages	2
Standards	QSFP28, 100GbE
Protocols	ST2022-6/7(D), ST2110, AES67, ST2059

SFP Cages

Number of cages	2
Standards	SFP28, 10GbE
Protocols	ST2022-6/7(A), ST2110, AES67, ST2059

Serial video inputs (optional)

Standard	UHD SMPTE ST 2082, HD-SDI ST292, ST296 ST274 3G-SDI ST424 (Level A) ST425-1
Number of Inputs	8
Connector type	Micro BNC (HD BNC)
Signal Level	800mV
DC Offset	0V±0.5V
Overshoot	Within 10% of signal level
Return Loss	>15dB up to 1.5GHz, >10dB up to 3GHz

Audio shuffler

Protocol	SWP08
----------	-------

Serial video outputs (optional)

Standard	UHD ST2082, HD-SDI ST292/ST296/ST274 3G-SDI ST424 (Level A)/ST425-1
Number of Inputs	8
Connector type	Micro BNC (HD BNC)
Signal Level	800mV
DC Offset	0V±0.5V
Overshoot	Within 10% of signal level
Return Loss	>15dB up to 1.5GHz, >10dB up to 3GHz

Serial video bi-directional connections (optional)

Standard	HD-SDI ST292/ST296/ST274 3G-SDI ST424 (Level A)/ST425-1
Number of Inputs	24
Connector type	Micro BNC (HD BNC)
Signal Level	800mV
DC Offset	0V±0.5V
Overshoot	Within 10% of signal level
Return Loss	>15dB up to 1.5GHz, >10dB up to 3GHz

Video compression

Video compression	JPEG XS by IntoPIX
Encapsulation	JPEG XS in RTP/UDP/IP, ST110-22 IETF RTP Payload for JPEG XS
Encoding/Decoding	Up to 6/12 channels of encoding/decoding Compression ratio 5:1 to 40:1
	OJG1212-16-G 12 FHD/HD/SD enc/dec
	OJG0606-6-U 6 UHD/FHD/HD/SD enc/dec
Video sampling	YCbCr, 4:2:2 10 bit

Miscellaneous

Weight	Approx. 2050gr
Operating temp.	0°C to +40°C
Dimensions	400 x 193 x 42mm (LxWxD)

Electrical

Voltage	+12V nominal (tolerance:-1V/+0.5V)
Power	100-120Watts